

URBANWOOD À LA CARTE PROGRAM

Your Project, Your Way

Discover how the À LA CARTE program caters to your budget, species, grade & colour needs

See the Video!



SKYLINE SERIES

Skyline features Natural Grade European Oak on a eucalyptus plywood core, and is available in a plethora of fashion forward, designer approved colours. Skyline is a recommended option for when visual appeal and cost performance are top considerations.

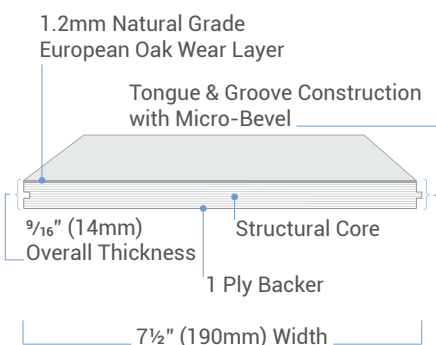

THE À LA CARTE PROGRAM

UrbanWood's À LA CARTE is a program that offers designers, specifiers and construction management professionals maximum flexibility to mix and match colours, specs and platforms and create their unique, perfectly customized flooring solution for any major project.

À LA CARTE grants design professionals creative free rein to choose any colour they wish, while offering a wide selection of available platforms that will satisfy construction requirements and keep the project on budget. For more info visit urbanwoodfloor.com/platforms

- Width** - 7 1/2" (190mm) width
- Length** - comes in a 75" (1,900mm) box with 70% full lengths
- Skyline Series Engineered Construction** - eucalyptus core with a 1.2mm European oak wear layer
- DuRa Finish Ultra Matte** - looks natural and harmonizes with wood's natural texture, while offering superior protection
- DuRa Finish Commercial** - superior wearing commercial finish available as an upgrade
- GREENGUARD Gold** - certified to ensure a healthy living environment with excellent indoor air quality



- Connection System** - Tongue and groove
- Installation** - Below, on, or above grade
- Available in a wide spectrum of colours** - refer to the UrbanWood Colours Box
- Herringbone and Chevron options** - for creating visually stunning spaces
- Accessories available** - for the utmost in design flexibility
- All Urbanwood floors** - are made in a state-of-the-art wood flooring manufacturing facility that is fully owned and managed by Creative At Home Enterprises Inc. The facility runs on green, renewable energy, is Zero-Waste Certified, and is designed to provide a healthy, VOC-free working environment for its employees. For more info visit urbanwoodfloor.com/sustainability